

# BANNER ROD/HANGING RACK CEILING HUNG SYSTEM

BILL OF MATERIALS		
ITEM #	GRIPLOCK P/N	QTY.
1	DG-CC-CPLT-SAT	2
2	DAS-20-87-xxx*	2
3	DG-25-SMU-SAT	2
4	DG-CT-SAT	2

\*xxx is length of cable in inches.  
Stock lengths are 60", 120", 180" & 240"

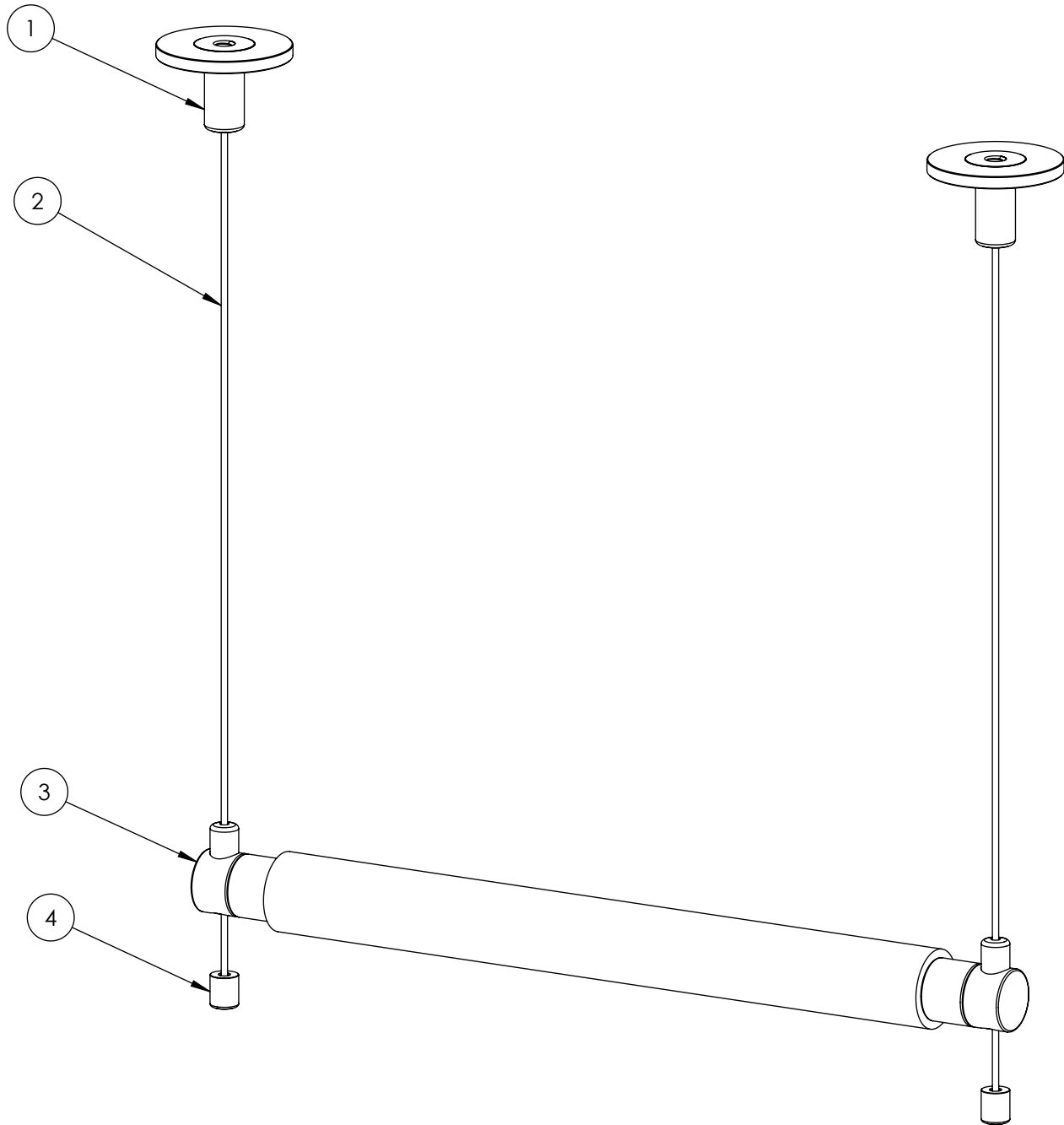

DATE: 08/27/08

SCALE: 1:2

FILE: Bannerrod - hanging rack  
ceiling hung system w ceiling  
cover plate

**PROPRIETARY AND CONFIDENTIAL**

This drawing and these specifications are the exclusive property of GRIPLOCK SYSTEMS LLC and shall not be divulged, reproduced, copied, or used as the basis for the manufacture or sale of apparatus without the express written authorization of GRIPLOCK SYSTEMS LLC.



**GRIPLOCK SYSTEMS**

410 Palm Ave. Loft A18, Carpinteria, CA 93013  
Phone (805) 566-0064 Fax (805) 566-0065  
www.griplocksystems.com